

Finding the Curie Temperature for Ferromagnetic Materials

Czesław Kizowski, Sylwia Budzik, and Józef Cebulski, Institute of Physics, University of Rzeszów, Poland

The laboratory exercise described in this paper is based on a well-known qualitative demonstration of Curie temperature.¹ A long ferromagnetic wire, in the form of a spiral, is attracted to a strong permanent magnet placed near its midpoint (see Fig. 1). The temperature of the wire is increased by passing a current through it. When the temperature reaches the Curie point, the wire becomes paramagnetic and is no longer strongly attracted to the magnet. We have developed this demonstration into a quantitative experiment by providing an accurate way to determine the temperature at which the ferromagnetic-paramagnetic transition occurs.

Experiment

Figure 1 shows the experimental setup used in finding the Curie point. It is composed of a ferromagnetic material (Kanthal type D)² in the form of the spiral-heating element stretched vertically between insulating clamps mounted on the support stand. A permanent magnet is mounted near the middle of the support stand such that it visibly attracts the hanging spiral. The spiral is connected to the output of the auto-transformer (Variac). The current through the wire is measured with the ammeter (A), and the potential difference across it with the voltmeter (V).

Electrical energy W is delivered to the wire at a constant rate $P = VI$, where V and I are, respectively, the potential difference across the spiral and the current flowing through it. We may therefore write:

$$W = VI t, \quad (1)$$

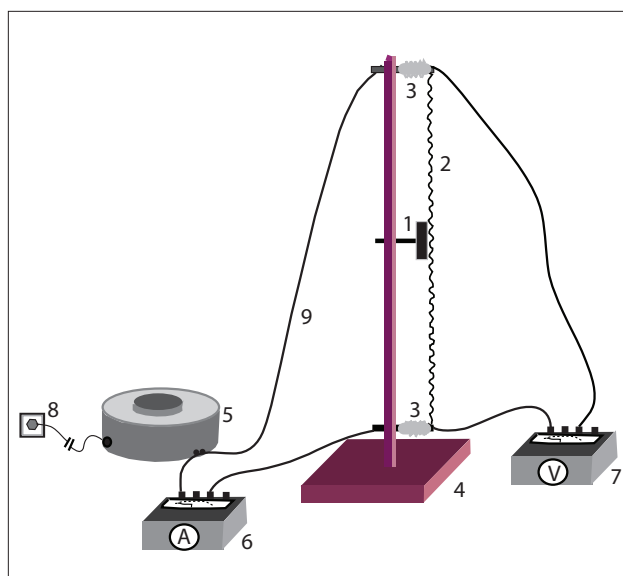

Fig. 1. Experimental setup.

where t is the amount of time the current has flowed. A portion of this energy increases the internal energy of the spiral, and another portion is radiated into the surrounding environment.

If a spiral of mass m and specific heat c is heated from an initial temperature T_0 to a higher temperature T , then the change in the internal energy of the spiral is expressed by:

$$\Delta E_t = mc(T - T_0). \quad (2)$$

Furthermore, the energy radiated out of the spiral is given by:³

$$E_p = e\sigma S(T^4 - T_0^4)t, \quad (3)$$

where S and e are, respectively, the surface area and emissivity³ of the spiral wire, and

$\sigma = 5.675 \times 10^{-8} \frac{W}{m^2 K^4}$ is the Stefan-Boltzmann constant.

The energy balance equation for the spiral wire is:

$$W = \Delta E_t + E_p$$

$$\text{or } VIt = \Delta E_t + E_p. \quad (4)$$

In our experiment, the voltage is set to the minimum level at which the heated spiral stops being attracted by the permanent magnet (the spiral loses its ferromagnetic properties and becomes a paramagnetic material). The temperature of the spiral at that point is the desired Curie temperature T_C .

After the spiral reaches a constant temperature, the ΔE_t term in Eq. (4) is equal to zero. Substituting Eqs. (1) and (3) into Eq. (4), we obtain:

$$VIt = e\sigma S(T^4 - T_0^4). \quad (5)$$

If $T = T_C$, then:

$$T_C = \sqrt[4]{\frac{VI + e\sigma ST_0^4}{e\sigma S}}. \quad (6)$$

Results and conclusions

The table gives typical data obtained for two different spiral wires.

Substitution into Eq. (6) gives for the two wires:

$$\text{Spiral a: } T_C = 858 \text{ K} \pm 6\text{K} = 581 \pm 6^\circ\text{C}$$

$$\text{Spiral b: } T_C = 869 \text{ K} \pm 6\text{K} = 596 \pm 6^\circ\text{C}$$

These values agree quite well with those found in tables of physical properties of materials.^{2,4} The unknown uncertainty in the emissivity of the wires was not included in the calculation of estimated uncertainties in the Curie temperatures. We did, however, use an optical pyrometer to check the accuracy of our

Properties of Spiral Wires	Spiral "a"	Spiral "b"
Diameter (d)	0.60 ± 0.01 mm	0.62 ± 0.01 mm
Length (l)	10400 ± 1 mm	7875 ± 1 mm
Surface area ($S = \pi dl$)	196 ± 4 cm ²	148 ± 3 cm ²
Emissivity (e) (Refs. 2, 4)	0.70	0.70
Voltage at Curie temperature (V)	147 ± 1 V	108 ± 1 V
Current at Curie temperature (I)	2.99 ± 0.01 A	2.92 ± 0.01 A
Nominal Curie Temperature (T_C) (Refs. 2, 4)	600°C	600°C

method. With the voltage and current values for spiral "b" equal to $V = 170 \text{ V} \pm 1\text{V}$ and $I = 4.45 \text{ A} \pm 0.01 \text{ A}$, respectively,⁵ its surface temperature was found to be $800^\circ\text{C} \pm 16^\circ\text{C}$ (2%) = $1073 \text{ K} \pm 16 \text{ K}$. Using Eq. (6) to calculate the temperature from the current, voltage, and other known parameters gives $T = 1058 \pm 7 \text{ K}$. The good agreement between the measured and calculated temperatures provides confidence in our method and suggests that the uncertainty in the emissivity of the wire is small.

References

1. R.M. Sutton, *Demonstration Experiments in Physics* (McGraw-Hill, New York, 1938), p. 292.
2. <http://www.kanthal.com>. This site includes specifications and physical properties of Kanthal D and other alloys.
3. H.S. Carslaw and J.C. Jaeger, *Conduction of Heat in Solids*, 2nd ed. (Oxford University Press, 1959), pp 18-21.
4. A table of physical and mechanical properties of Kanthal D as well as a number of related alloys may be found at (Propriedades Físicas e Mecânicas Ligas Kanthal) <http://www.casaferreira.com.br/aquecimento/fiosfitas/ligas.htm>.
5. 600°C was below the usable range for our optical pyrometer. In order to obtain reliable temperature readings, it was necessary to work well above the Curie temperature.

PACS codes: 01.50.Pa, 60.00.00

Czesław Kizowski is a professor at the University of Rzeszów in Poland. He has been teaching Didactics of Physics there since 1972. He holds an M.Sc and Sc.D. in physics from the University of Gdansk. His current interests include teacher training and developing thinking processes as applied to learning physics. He is head of the Didactics of Physics Unit. He is personally interested in the usage of electronics, music, and skiing.

Sylvia Budzik has an M.Sc. in physics. She has been teaching Didactics of Physics since 2004 at the University of Rzeszów in Poland. She is working at the Physics Institute in Didactics of Physics Unit. She deals with nanotechnology as a new part of school physics.

Józef Cebulski has been teaching solid state physics since 1994 at the University of Rzeszów in Poland. He holds an M.Sc. and Sc.D. in physics from the University of Rzeszów. His interests are connected with solid state physics, narrow-gap semiconductors, and resonance phenomena in strong magnetic fields in semiconductors. He is a coauthor of more than 10 articles (with Philadelphian list) from domain of semiconductor physics.

Institute of Physics, University of Rzeszów, Poland
